

SLIT INTERDIGITAL MICROMIXER

SIMM GROUP CLASS SIMM-V2, HPIMM, SIMHEX, SSIMM

54

03



SIMM group class

Principle

This group class of micromixers is a classic amongst all IMM chemical micro processing products. It has been used by a large number of customers, is cited multiple times in literature, and is indeed one of our best sellers.

They combine the regular flow pattern created by multi-lamination with geometric focussing which speeds up liquid mixing.

Due to this double-step mixing, the slit mixers are amenable to wide variety of processes such as mixing, emulsification, single-phase and multiphase organic synthesis. Extensive knowledge on hydrodynamics, mixing performance and reaction engineering for diverse applications of these mixers has been documented worldwide.

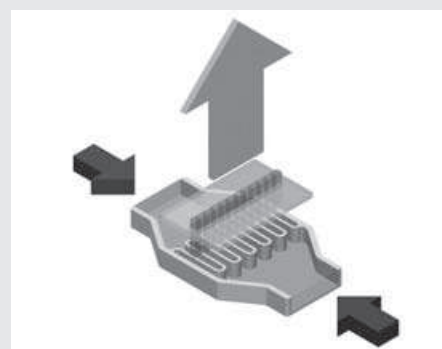

Interdigital flow passes slit to create multi-lamellae

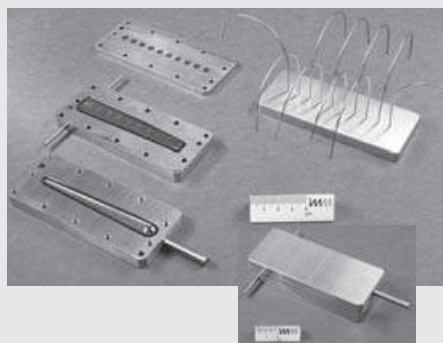

Research Topics at IMM

One important task at IMM is the continuous advancement of our components for the use in production. The pictures here show our latest efforts for a 10-fold scaled-up version of the SIMM-V2 mixer (ARRAY-10x-Slit Interdigital Micromixer), combining the unique properties of the interdigital mixers and their small structures with the wish to process larger throughputs.

Ten mixing elements are operated in parallel using common feed structures. Two kinds of upper housings have been realised: One collecting all ten single outlet streams in one and one with ten separated outlets. The latter allows systematic equidistribution measurements. The device has been developed for a liquid/liquid dispersion step.

SIMM-V2

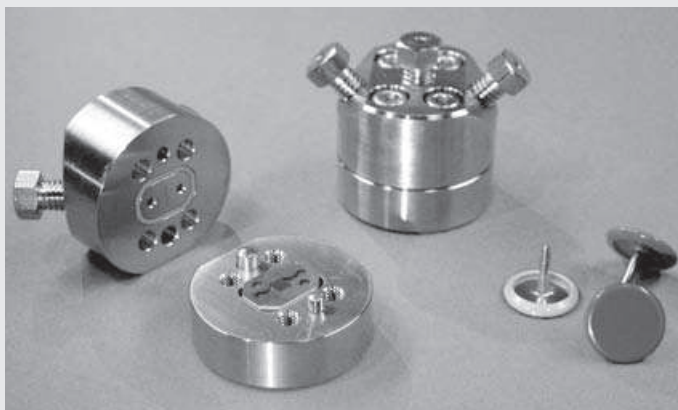

Individual parts of the SIMM-V2 device

Principle

This version has all the benefits of mixing using multi-lamination and focusing only. Deliberately avoiding volume expansion, the inner volume could be decreased to only 8 μl , coming along with improved fluidic connections, e. g. to pumps and tube reactors, as it employs HPLC connectors. Compared to the connectors of the standard version SSIMM, the HPLC joint to steel tubing improves leak tightness and higher pressure operation can be achieved.

Technical Data

Order number	SIMM-V2
Mixing principles	Multi-lamination
Size (L x B x H)	30 x 40 x 30
Connectors (Inlet/Outlet)	1/16" / 1/16" HPLC
Standard mixing channels (μm)	45 x 200
Standard material	Body: 1.4571 Inlay: 1.4435
Options	Other materials like Hastelloy, Monell or Titan on request

Operating Conditions

Temperature ($^{\circ}\text{C}$)	-40 – 220
Pressure stability (bar)	100
Flowrate (l/h)	0.04 – 2.5
Residence time (ms)	14.4 – 720
Inner volume (μl)	8
Max Viscosity (mPas)	10000
Leakage Class	< $L_{0.001}$

HPIMM



Individual parts of the HPIMM

Principle

This micromixer was optimized using a metal sealing for tightening the two parts of the housing. As a consequence, the limits of pressure and temperature during operation are much higher than for flat-seal tightened devices. The mixer also comprises expansion-free outlet channel geometry, i.e. renounces on jet mixing, but relies on multi-lamination and geometric focusing only.

Technical Data

Order number	HPIMM
Mixing principles	Multi-lamination
Size (L x B x H)	25 x 21 x 37
Connectors (Inlet/Outlet)	1/16" / 1/16" HPLC
Standard mixing channels (μm)	approx. 45 μm x 200 μm
Standard material	Body: 1.4571 Inlay: 1.4401
Options	Other materials like Hastelloy, Monell or Titan on request

Operating Conditions

Temperature ($^{\circ}\text{C}$)	-40 – 500
Pressure stability (bar)	600
Flowrate (l/h)	0.04 – 2.5
Residence time (ms)	27 – 1350
Inner volume (μl)	15
Max Viscosity (mPas)	10000
Leakage Class	< $L_{0.001}$

SLIT INTERDIGITAL MICROMIXER

SIMM GROUP CLASS SIMM-V2, HPIMM, SIMHEX, SSIMM

56

SIMHEX

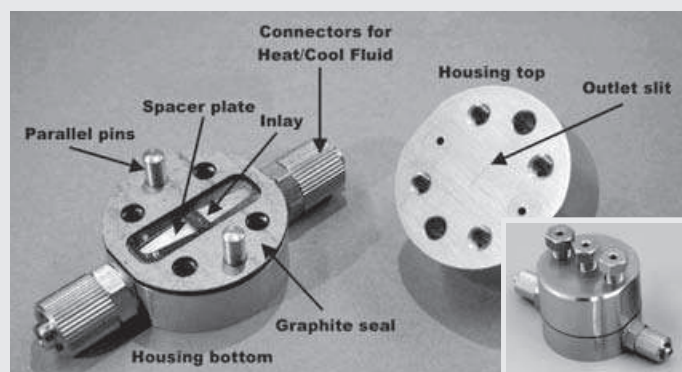

Slit Interdigital Mixer Heat Exchanger (SIMHEX)

Principle

This micromixer was optimized considering a heat exchange function within the mixer, using a graphite sealing for tightening the two parts of the housing. As a consequence, the limits of pressure and temperature during operation are limited but conveniently provide the possibility of heating or cooling the device. The mixer also comprises expansion-free outlet channel geometry, i.e. renounces on jet mixing, but relies on multi-lamination and geometric focussing only.

Technical Data

Order number	SIMHEX
Mixing principles	Multi-lamination
Size (L x B x H)	25 x 25 x 20
Connectors (Inlet/Outlet)	1/16" / 1/16" HPLC
Standard mixing channels (µm)	40 x 300
Standard material	Body: 1.4571 Inlay: 1.4401
Options	Other materials like Hastelloy, Monell or Titan on request; incl. heat exchanger function

Operating Conditions

Temperature (°C)	-100 – 500
Pressure stability (bar)	50
Flowrate (l/h)	0.04 – 2.0
Residence time (ms)	18 – 900
Inner volume (µl)	10
Max Viscosity (mPas)	10000
Leakage Class	< L _{0.001}

SSIMM

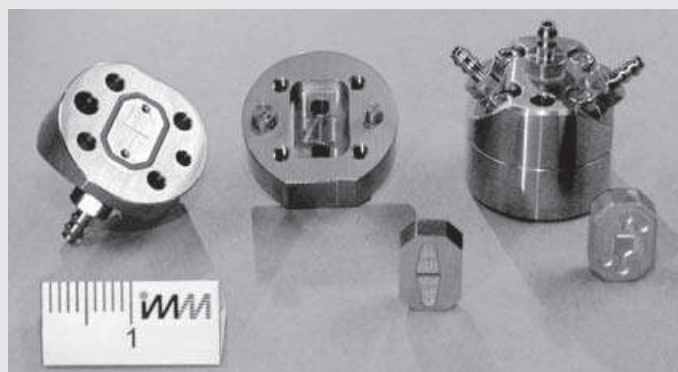

Standard Slit Interdigital Micromixer (SSIMM)

Principle

This micromixer is the classic one amongst all IMM chemical micro processing products. It combines the regular flow pattern created by multi-lamination with geometric focussing and subsequent volume expansion, which speeds up liquid mixing of the multi-lamellae and leads to jet mixing. Due to the volume expansion the mixer contains an inner volume of 40 µl and is only offered with non-stainless soft tube connectors.

Technical Data

Order number	SSIMM
Mixing principles	Multi-lamination
Size (L x B x H)	19 x 30 x 16.5
Connectors (Inlet/Outlet)	1/16" / 1/16" soft tube
Standard mixing channels (µm)	45 x 200
Standard material	Body: 1.4571 Inlay: 1.4435
Options	Other materials like Hastelloy, Monell or Titan on request

Operating Conditions

Temperature (°C)	-20 – +100
Pressure stability (bar)	3
Flowrate (l/h)	0.04 – 1.5
Residence time (ms)	72 – 3600
Inner volume (µl)	40
Max Viscosity (mPas)	10000
Leakage Class	< L _{0.001}

Slit mixer inlays SMI (for SIMM-V2 and SSIMM)

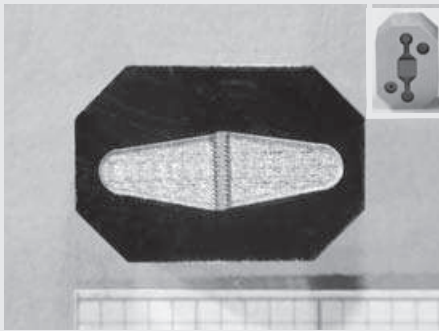

Laser ablation Inlay for SIMM-V2 and SSIMM

This inlay fits the standard mixer as well as the version 2.

For both versions the inlays have a size of 11.0 mm x 7.5 mm and ~ 3.6 mm thickness with different possible channel sizes and depths.

The following inlays are available:

- Laser-ablation (channel width 45 μm , 200 μm channel depth) made of stainless steel (SS 316L) as standard but other materials like Hastelloy etc. or other channel dimensions on request, order number SMI-Lasab45200
- LIGA technology (channel width 25 μm or 40 μm) made from silver or nickel on copper with 300 μm channel depth, order numbers SMI-Ni25, SMI-Ni40, SMI-Ag25 or SMI-Ag40
- ASE (thermally oxidised silicon, channel width 30 μm or 50 μm) with 100 μm channel depth, order numbers SMI-Si30 or SMI-Si50. As these inlays are only 0.6 mm thick, extra bases of 3.0 mm thickness are needed

SIMHEX inlays SMHXI

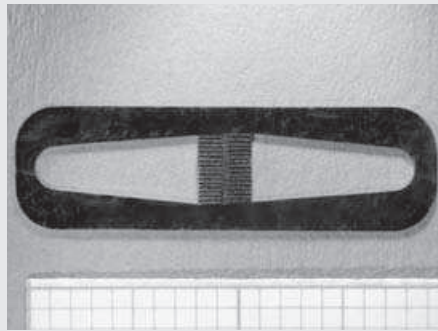

Laser-cut Inlay for SIMHEX

This inlay fits the slit interdigital mixer heat exchange exclusively.

The size of SMHXI inlays:
20 mm x 6 mm

The following inlays are available:

- Laser-cutted inlays (channel width 45 μm , 250 μm channel depth) made of stainless steel (SS 316L) as standard but other materials like Hastelloy etc. or other channel dimensions on request, order number SMHXI-45250

High pressure mixer inlays HPMI

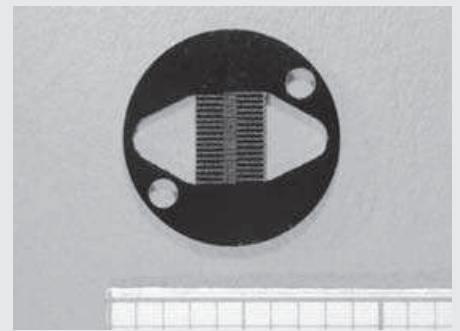

Laser-cut Inlay for HPIMM

This inlay fits the high-pressure slit mixer exclusively.

The size of HPMI inlays:
8.0 mm in diameter and 250 μm in thickness

The following inlays are available:

- Laser-cutted inlays (channel width 45 μm , 250 μm channel depth) made of stainless steel (SS 316L) as standard but other materials like Hastelloy etc. or other channel dimensions on request, order number HPMI-Las45250

